

# Working on roofs

Working on a roof can be dangerous. Falls account for more deaths and serious injuries in construction than anything else and roofers account for 24% – the biggest category of worker by far – of those people who are killed in all falls from height.

Any fall from a roof inevitably involves at least a serious injury. The risks are substantial, however long or short the work. Many have been killed who only meant to be on the roof for a few minutes 'to have a quick look' or to carry out a small repair.

This leaflet is aimed at people who actually carry out roof work or are directly responsible for managing or supervising it. It sets out key safeguards, but more detailed information is contained in *Health and safety in roof work* HSG33.

Falls occur:

- from the edges of roofs;
- through gaps or holes in roofs; and
- through fragile roof materials and roof lights.

In addition, many people have been seriously injured by material falling or thrown from roofs.

Accidents don't just happen to those building roofs, but also to people maintaining, cleaning, demolishing and inspecting them.

Any work on a roof is high risk because it involves work at height. High safety standards are essential, however long or short term the work is. The nature of the precautions needed may vary from one job to another.

This leaflet sets out precautions that are relevant for all roof work and then describes precautions that are particularly relevant to different types of roof.

Don't chance it  
**CHANGE IT**

## Planning roof work

The **Work at Height Regulations 2005** set out a hierarchy which should be followed when planning any work at height. The hierarchy should be followed systematically and only when one level is not reasonably practicable may the next level down be considered.

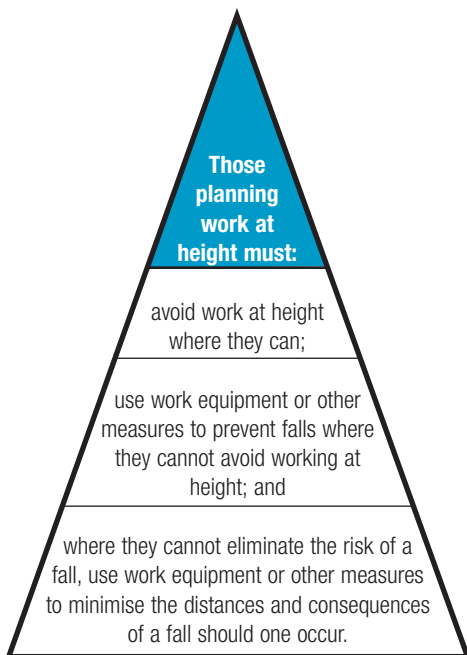

**Figure 1** The hierarchy for work at height

Those planning work at height must:

- **avoid work at height where they can**, eg:
  - consider carefully whether cleaning a roof for no other reason than appearances is actually necessary;
  - use a mobile elevating work platform (MEWP), telescopic pole with camera attachment or binoculars from a safe position on an adjacent building to carry out an inspection;
- **use work equipment or other measures to prevent falls where work at height cannot be avoided**, eg:
  - by using an existing (950 mm minimum height) parapet wall;
  - erecting edge protection;
  - using a MEWP to carry out the work; or
  - using a work-restraint system;
- **where they cannot eliminate the risk of a fall, use work equipment or other measures to minimise the distance and consequences of a fall should one occur**, eg:
  - by using nets, air or bean bags or a fall-arrest harness system.

Those in control of the work must also:

- always consider measures that protect all those at risk, ie **collective protection systems** such as scaffolds, nets, soft landing systems, before measures that only protect the individual, ie **personal protection measures** such as harnesses;
- always consider **passive** systems such as nets (where the individual does not have to do anything to activate the system) before **active** systems such as harnesses (where the worker has to clip on); and
- make sure work is carried out only when weather conditions do not endanger the health and safety of workers.

## Precautions for all roof work

### *Risk assessment and method statements*

You should carry out a risk assessment for all roof work. Simple jobs may not require a great deal. More complex jobs need to be assessed in much more depth. But all roof work is dangerous and it is essential that you identify the risks before the work starts and that the necessary equipment, appropriate precautions and systems of work are provided and implemented.

Except for the simplest jobs where the necessary precautions are straightforward and can be easily repeated (eg use a proper roofing ladder to replace a ridge tile), you should prepare safety method statements. They should be specific and relevant to the job in hand and clearly describe the precautions and system of work identified during risk assessment. Diagrams or pictures can often say more and be clearer than text. Everyone involved in the work needs to know what the method statement says and what they have to do. This might need someone to explain the statement for more complicated jobs. There will usually need to be some supervision during the work to check that the correct procedures are followed.

### *Getting on and off the roof*

Getting on and off the roof is a major risk. A secure means of entry and exit is essential. A general access scaffold, tower scaffold (preferably of the stairway design) provides suitable access. A properly secured ladder is the minimum requirement.

### *Edge protection*

Wherever anyone could fall, the first line of defence is to provide adequate edge protection to **prevent** a fall occurring. This should include or be equivalent to:

- a main guard rail at least 950 mm above the edge;
- a toe board and brick guard where there is risk of objects being kicked off the edge of the platform; and
- a suitable number of intermediate guard rails or suitable alternatives positioned so that there is no gap more than 470 mm.

Sometimes a roof parapet may provide equivalent protection but if it does not, extra protection will be required.

### *Work platforms*

As well as edge protection, it is just as important to provide an adequate and secure working platform from which to carry out the work. In many cases the roof itself will provide this. If it does not (eg when working on a chimney on a pitched roof), a platform should be provided. If appropriate, a MEWP may be suitable for some work where it can be carried out from inside the basket.

### *Fall mitigation*

Providing adequate platforms and edge protection may not always be possible or reasonably practicable. If so, safety nets or soft landing systems, such as bean bags or inflatable air bags, can **minimise** the consequences of any potential injury.

If nets are used make sure that they are properly installed by competent riggers as close under the work surface as possible to minimise the distance fallen. Installing a net does not mean that proper working platforms and edge protection can be ignored – the first priority is to stop people falling in the first place.

Personal fall arrest systems (such as harnesses), which only protect the individual, should be seen as lower down the hierarchy as they do not prevent the fall, only minimise the consequences and protect the individual worker. In addition, these systems require a sufficiently strong anchorage point, user discipline and active monitoring by management.

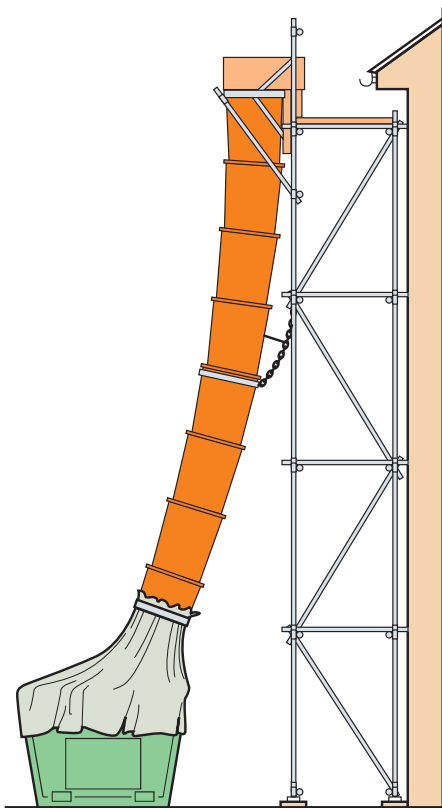

**Figure 2** Rubbish chute and skip are positioned to take waste materials

### Falling material

Keep a tidy site: stop material which could fall from accumulating.

Never throw anything from a roof or scaffold. Use enclosed rubbish chutes or lower material to the ground in containers.

Prevent access to danger areas underneath or adjacent to roof work. Where this cannot be guaranteed, consider using debris netting, fans, covered walkways or similar safeguards to stop falling material causing injury.

Particular care is needed where there is public access close to roof work. If possible, try to arrange for work to be carried out when passers-by will not be there, eg carry out repairs to schools during the school holidays. If this cannot be arranged, minimise public access to danger areas. In some cases physical protection to catch falling materials, eg scaffold fans or debris netting, may be appropriate. Remember that even fine material such as dusts can cause discomfort or eye injuries.

### Training

Roof workers need the appropriate knowledge, skills, training and experience to work safely, or should be under the supervision of someone else who has it. They need to be able to recognise the risks, understand the appropriate systems of work and be competent in the skills to carry them out such as:

- installing edge protection;
- operating a MEWP;
- manually handling materials;
- erection of tower scaffolds; and
- installing and wearing harness systems (including rescue procedures).

Workers need training and experience to achieve these competencies. It is not enough to hope that they will 'pick up safety on the job'.



**Figure 3** Proprietary access system for roof work

### Weather conditions

The Work at Height Regulations 2005 specifically state that work should not be carried out if weather conditions could endanger the health and safety of workers. Do not work on roofs in icy, rainy or windy conditions. Anyone carrying a roof sheet can easily be blown off the roof if they are caught by a gust of wind.

Avoid excessive exposure to sunlight by wearing appropriate clothing and using sun creams. Too much exposure to sunlight can cause skin cancer.

### Short-duration work

Short-duration work means tasks that are measured in minutes rather than hours. It includes tasks such as inspection, replacing a few tiles or minor adjustment of a television aerial. It may not be reasonably practicable to provide full edge protection for short-duration work but you will need to provide something in its place.



**Figure 4** A mobile elevating work platform being used to replace a roof sheet

The minimum requirements for short-duration work on a roof are:

- a safe means of access to the roof level; and
- a safe means of working on the roof (eg on a sloping roof, a properly constructed roof ladder, or on a flat roof, a harness with a sufficiently short lanyard that it prevents the wearer from reaching a position from which they could fall and attached to a secure anchorage).

Mobile access equipment or proprietary access systems can provide a suitable working platform from which to carry out some work. They can avoid the need for scaffolding and can be particularly appropriate for short-duration minor work.

## Fragile roofs

### What is fragile?

Falls through fragile roofs account for 22% of all the deaths that result from a fall from height in the construction industry. A fragile material is one that does not safely support the weight of a person and any load they are carrying. The fragility of a roof does not depend solely on the composition of the material in it, the following factors are also important:

- thickness of the material;
- the span between supports;
- sheet profile;
- the type, number, position and quality of fixings;
- the design of the supporting structure, eg the purlins; and
- the age of the material.

Remember that even those roofs that were deemed to be 'non-fragile' when they were installed will eventually deteriorate and become fragile over time.

Sometimes the entire roof surface is fragile, such as many fibre cement roofs. Sometimes part of the roof is fragile, eg when fragile roof lights are contained in an otherwise non-fragile roof. Sometimes a roof is temporarily fragile, such as during 'built up' roof construction when only the liner is installed or sheets have not been secured. Sometimes the fragility of a roof may be disguised, eg when old roofs have been painted over. This guidance applies to all these situations.

The fragility, or otherwise, of a roof should be confirmed by a competent person before work starts. If there is any doubt, the roof should be treated as fragile unless, or until, confirmed that it is not. It is dangerous to assume that a roof is non-fragile without checking this out beforehand.

### Prevent unauthorised access

Make sure that unauthorised access to the roof is prevented, eg by implementing a permit-to-work regime or blocking off roof access ladders. Make sure that appropriate warning signs are displayed on existing roofs, particularly at roof access points.

### Working on fragile materials

Work on fragile materials must be carefully planned to prevent falls through the roof:

- all work should be carried out from beneath where this is practicable;
- where this is not possible, consider using a MEWP that allows operatives to carry out the work from within the MEWP basket without standing on the roof itself;

- if access onto the fragile roof cannot be avoided, edge protection should be installed around the perimeter of the roof and staging should be used to spread the load. Unless all the access and work is on staging and platforms that are fitted with guard rails, safety nets should be installed under the roof or a harness system should be used.

Where harnesses are used, they require adequate anchorage points. They also rely on user discipline, training and supervision to make sure that they are used consistently and correctly.

Support platforms should be of sufficient dimensions to allow the worker to move safely and use any equipment or materials safely.

Make sure that support platforms are long enough to provide adequate support across roof members. They should span across at least two purlins. Using a platform may spread the load, but it will not provide enough support if the only thing supporting it is the fragile material.

**Never** try to walk along the line of the roof bolts above the purlins or along the ridge, as the sheets can still crack and give way; they are not designed to support your weight.

Workers should not have to constantly move platforms about the roof. It is not acceptable to rely on using a pair of boards to 'leap-frog' across a fragile roof. Make sure there are enough platforms provided to avoid this.

Precautions are needed to prevent a person falling from the platform. Provide the platform with edge protection comprising top rail, intermediate rail (or equivalent protection) and toe board.

### Working near fragile material

Protection is needed when anyone passes by or works near to fragile materials, eg:

- during access along valley gutters in a fragile roof;
- when fragile roof lights or smoke vents are contained in an otherwise non-fragile roof; or
- during access to working areas on a fragile roof.

Wherever possible make sure that all fragile materials 2 m or closer to the people at risk are securely covered and a warning notice displayed. Alternatively, provide continuous barriers with warning notices around or along the fragile material to prevent access to it. (Make sure that appropriate precautions are taken when installing such protection, eg the use of netting, birdcage scaffold or a harness system.)

Sometimes it will not be reasonably practicable to provide such protection, usually if the proximity to fragile material is irregular and short duration, ie a matter of minutes. Safety harnesses will usually be the appropriate solution and may be used in conjunction with any permanently installed running line systems.

Boundaries can be established identifying 'safe' areas containing the workplace and routes to and from it. If these are used:

- the boundary should be at least 2 m from the nearest fragile material;
- the boundary does not need to comply with full edge protection standards, but there should be a continuous physical barrier (a painted line or bunting is not acceptable); and
- tight discipline is essential to make sure everyone stays inside the safe area at all times.

## Working on sloping roofs

On traditional pitched roofs most people fall:

- from eaves;
- by slipping down the roof and then over the eaves;
- through the roof internally, eg during roof truss erection; or
- from gable ends.

### Edge protection

Full edge protection at eaves level will normally be required for work on sloping roofs. The edge protection needs to be strong enough to withstand a person falling against it. The longer the slope and the steeper the pitch, the stronger the edge protection needs to be. A properly designed and installed independent scaffold platform at eaves level will usually be enough. Less substantial scaffolding barriers (rather than platforms) may not be strong enough for work on larger or steeper roofs, especially slopes in excess of 30°.

On some larger roofs, the consequences of sliding down the whole roof and hitting edge protection at the eaves may be such that intermediate platforms are needed at the work site to prevent this happening.

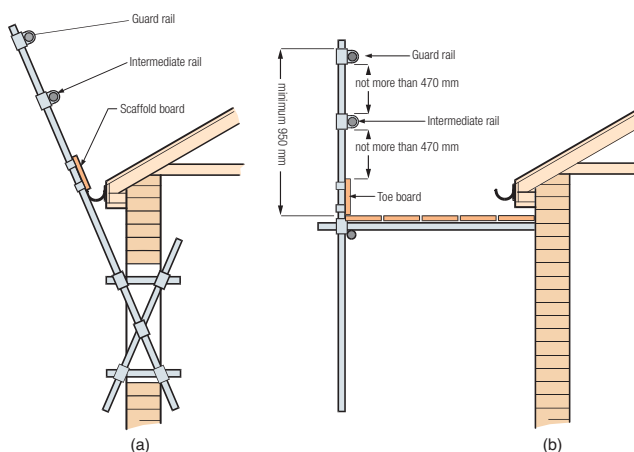

**Figure 5** Typical sloping roof edge protection. Barriers shown in (a) can be useful where space is limited, but they are not capable of sustaining loads as large as (b), which also provides a working platform

If the work requires access within 2 m of gable ends, edge protection will be needed there as well as at the eaves. Alternatively, consider using MEWPs (Figure 4) or proprietary access systems (Figure 3), which are easy to transport from site to site, quick to erect and provide good access, as an alternative to fixed edge protection where appropriate for the work you are planning.

### Roof ladders

On sloping roofs, roof workers should not work directly on slates or tiles, as they do not provide a safe footing, particularly when they are wet. Use roof ladders and proprietary staging to enable safe passage across a roof. They must be designed for the purpose, of good construction, properly supported, and, if used on a sloping roof, securely fixed by means of a ridge hook placed over the ridge, bearing on the opposite roof. They should be used in addition to eaves-level edge protection. Gutters should not be used to support any ladder.

## Short-duration work on sloping roofs

Short-duration work means tasks that are measured in minutes rather than hours. It includes tasks such as inspection, replacing a few tiles or minor adjustments to a television aerial. **Work on a roof is still dangerous even if it only lasts a short time. Appropriate safety measures are essential.**

It may not be reasonably practicable to provide full edge protection for short-duration work but you will need to provide something in its place. The minimum requirements for short-duration work on a roof are:

- a safe means of access to the roof level; and
- a properly constructed and supported roof ladder.

Mobile access equipment can provide a suitable working platform from which to carry out some work. It can do away with the need for scaffolding and can be particularly appropriate for short-duration minor work.

### Erecting roof trusses

If possible, reduce the need for work at height by assembling roof sections on the ground and craning them into position.

If trusses are assembled in situ, provide a safe working platform around the perimeter of the roof together with measures to mitigate the distance and consequences of a fall should one occur. This can be achieved by providing a working platform or 'crash deck' immediately beneath the underside of the trusses. Either conventional scaffolding, or (if appropriate) proprietary plastic decking systems can be used for this. Alternatively, nets can be used if a safe clearance distance can be achieved below the net and a suitable fixing point is available. Alternatives to nets are soft landing systems such as bean or air bags. Providing nets or soft landing systems is particularly important when installing temporary bracing or before boarding out along the bottom chord of trusses where access is required within the trusses.



**Figure 6** Roof truss built on ground and lifted into position avoiding the need to work over open joisting later on

## Industrial roofing

Building and working on steel-framed wide-span industrial roofs involves a number of hazards, such as falls:

- from the roof edge;
- through gaps in the partially completed roof;
- through fragile liner panels or roof lights;
- from the leading edge when unprotected gaps are inevitable; and
- from the frame, eg when loading out with roof sheets.

These hazards can all arise not only at the working position but also the routes to and from it.

The preferred standard of protection for industrial roof work is edge protection fitted to the perimeter, with nets used in conjunction with staging or work platforms when roof sheets are being fixed.

### Systems of work

Good planning and consideration of the hierarchy for work at height can significantly reduce the risks involved in industrial roofing. Consider reducing the need for operatives to move around the roof unnecessarily by:

- arranging for the right sheets to be delivered as they are needed, to the right place at the right time;
- splitting packs of roof sheets to produce mixed packs in the correct sequence for fixing;
- arranging access points that are convenient for the working position; and
- making full use of loading bays.

### Falls from the roof edge

Full edge protection (top rail, toe board and intermediate protection) is required whenever the work requires access within 2 m of the roof perimeter. Edge protection is usually provided by an independent scaffold around the perimeter of the building or by barriers connected to the frame. An independent scaffold gives a higher standard of protection and a good standard of access along the structure. It also assists material loading and storage, eg when used with a fork lift/telehandler.

Netting capable of providing edge protection in certain circumstances is now available.

### Falls through gaps

If the work involves any likelihood of access within 2 m of such gaps they should be covered with a material which is fixed in position and sturdy enough to take the weight of a person. If this is not possible, provide edge protection around the gap or as a last resort install safety netting beneath the gap.

### Falls through liner panels

Liner panels on their own should be considered as fragile unless it has been conclusively confirmed that they are not.

### Falls from the leading edge

Whatever system of work you choose, the presence of dangerous gaps is always a possibility as space is created to place the next leading edge sheet. Options to deal with this include:

- safety nets;
- temporary barriers at the leading edge, such as trolley systems;
- birdcage scaffolds; or
- safety harnesses used with running line systems.

Safety netting is the preferred fall-arrest option as it provides collective protection and does not rely on individual user discipline to guarantee acceptable safety standards. Using nets can simplify systems of work and protect both roof workers and others, such as supervisors.

If safety nets are used make sure that they:

- are installed as close as possible beneath the roof surface;
- are securely attached and will withstand a person falling onto them; and
- are installed and maintained by competent personnel.

Trolley systems can be a useful aid, but for many reasons are often not practical or appropriate for all roofs, eg where there are hips or dormers. Remember that installing and moving such systems can involve significant risks.

If trolley systems are used, the system of work needs to be carefully thought out to avoid unnecessary risks, eg can roof workers lock the trolley in position after it has been moved forward without stepping over the newly created gap?



**Figure 7** Safety nets installed prior to sheeting. Note that the net is fixed as close to the underside of the roof as possible to minimise the extent of any fall

Make sure that either safety nets or harnesses are used to protect against falls through the gaps created as the leading edge moves forward.

If harnesses and running line systems are used make sure that they:

- are securely attached to an adequate anchorage point (trolley guard rails are not usually strong enough);
- the running line and harness are compatible;
- are appropriate for the user and in good condition; and
- are actually and properly used – ensuring this requires tight discipline.

### Falling materials

Try to avoid leaving materials on the roof when the site is closed, especially at weekends and during holiday periods. If materials are left on the roof make sure that they are secured so that they cannot be blown off the roof by windy weather.

Make sure that toe boards are in place around the roof perimeter.

Control other trades' access to areas underneath roofing work, unless protection such as debris netting is provided which **ensures** protection for anyone working underneath.

### Manual handling

Handling awkward roof sheets is a particular problem for roof workers and can lead to back injuries which can cause a lifetime of pain and disability. The first question to ask is 'does the load need to be manually handled at all?' Consider whether the materials can be delivered directly to the point of use, possibly by crane or hoist, rather than being manually carried, pushed or pulled. Often this is necessary as some of the larger sheets on the market **must not** be manually handled due to their weight.

Where manual handling cannot be avoided, introduce systems which make manual handling easier. Provide workers with information about the weight of the loads they will have to carry. Handling teams of more than four people are **not** recommended due to the difficulty in co-ordinating the team members.

### Working on flat roofs

Work on a flat roof is high risk. People can fall:

- from the edge of a completed roof;
- from the edge where work is being carried out; or
- through openings or gaps.

### Edge protection

Unless the roof parapet provides equivalent safety, temporary edge protection will be required during most work on flat roofs. Both the roof edge and any openings in it need to be protected. It will often be more appropriate to securely cover openings rather than put edge protection around them. Any protection should be:

- in place from start to finish of the work; and
- strong enough to withstand people and materials falling against it.

Where possible the edge protection should be supported at ground level, eg by scaffold standards, so that there is no obstruction on the roof. If the building is too high for this, the roof edge upstand can support the edge protection provided it is strong enough. Edge protection can also be supported by frames, counterweights or scaffolding on the roof. The protection should be in place at all times. Guarding systems are widely available that enable roof repair work to carry on without removing any guard rails.

### Demarcating safe areas

Full edge protection may not be necessary if limited work on a larger roof involves nobody going any closer than 2 m to an open edge. In such cases demarcated areas can be set up, outside which nobody goes during the work or access to it. Demarcated areas should be:

- limited to areas from which nobody can fall;
- indicated by a continuous physical barrier (full edge protection is not necessary but a painted line or bunting is not sufficient); and
- subject to tight supervision to make sure that nobody strays outside them (demarcation areas are unacceptable if this standard is not achieved).

### Short-duration work on flat roofs

'Short duration' means a matter of minutes rather than hours. It includes such jobs as brief inspections or minor adjustment to a television aerial.

**Work on a flat roof is still dangerous even if it only lasts a short time. Appropriate safety measures are essential.**

It may not be reasonably practicable to provide edge protection during short-duration work. The minimum requirements for short-duration work on a roof are:

- a safe means of access to the roof level; and
- a safe means of working on the roof – a harness with a sufficiently short lanyard that it prevents the wearer from reaching a position from which they could fall and attached to a secure anchorage.

Where safety harnesses are used they must be:

- appropriate for the user and in good condition;
- securely attached to an anchorage point of sufficient strength; and
- actually used – tight management discipline is needed to ensure this.

## Further reading

*Managing health and safety in construction. Construction (Design and Management) Regulations 2007. Approved Code of Practice L144* HSE Books 2007 ISBN 978 0 7176 6223 4

*Health and safety in roof work* HSG33 (Second edition) HSE Books 1998 ISBN 978 0 7176 1425 7  
(Being revised)

*Health and safety in construction* HSG150 (Third edition) HSE Books 2006 ISBN 978 0 7176 6182 4

**This leaflet contains notes on good practice which are not compulsory but which you may find helpful in considering what you need to do.**



**50% recycled**  
This leaflet is printed on 50% recycled paper

For detailed information, see [hse.gov.uk/shatteredlives](http://hse.gov.uk/shatteredlives)  
Or call HSE's Infoline on 0845 345 0055 for further information