

Safety Notes

Before Erection

- 1 Ensure that the instruction guide has been read & understood by anyone using the equipment. If in doubt contact your supplier.
- 2 All components should be checked for damage. Do not use damaged or incompatible equipment. Make sure that you have the correct amount of components.
- 3 Make sure the ground surface you are working on is firm & clear of obstruction.
- 4 Be careful not to infringe on any local bylaws when erecting mobile towers in public places and that warning signs are in place where necessary by law.
- 5 Do not erect any tower where there is a risk of contact with unprotected cables, unguarded machinery, or harmful substances.

Whilst Erecting The Tower

- 1 Always obey the height to base ratios. Outdoor freestanding towers should not exceed 3 times the smallest base dimension in height. For indoor use the height to base ratio is 3.5 : 1. If the heights exceed ratios the towers should be tied into a building or rigid structure.
- 2 Always take into account ground conditions. On soft ground a suitable base must be provided. (e.g Scaffold boards).
- 3 Ensure that the tower is level & vertical
- 4 Ensure stabilisers are fitted correctly when needed.
- 5 Ensure that the tower is not overloaded and that working loads are adhered to.
- 6 The Construction, Health & Safety & Welfare Regulations (1996) State that guardrail heights should be 1000mm and an intermediate guard rail be fitted so that there is a gap no larger than 470mm on any working or access platform located at 2m and higher above ground level.

Whilst Using The Tower

- 1 Do not exceed the safe working load of the tower.
- 2 Ensure a safe means of access is available & in place.
- 3 Ensure that castors are locked and that the tower is both level & vertical.
- 4 Beware of high wind conditions. Tie the tower to a rigid structure in exposed conditions where winds are up to Beaufort scale force 4 (17mph). If unsure about wind conditions consult your supplier.
- 5 If the tower is left unattended it must be secured against unauthorised usage or adverse weather conditions.
- 6 Never lean a ladder against the tower, only use the recommended ladder.
- 7 Do not use the adjustable legs to gain extra height, they are for levelling the tower only.
- 8 For linking towers or special applications always consult your supplier.
- 9 Limit the horizontal force on the tower to 20kg (44lbs) on freestanding tower.
- 10 If moving the tower always follow the procedure laid out below:
- 11 It is not permissible to attach and use hoisting arrangements on towers unless specifically provided by design.
- 12 It is not permissible to attach bridging between a tower and a building.
- 13 It is forbidden to jump onto platforms from buildings or other structures.
- 14 Towers used outdoors shall, whenever possible, be secured to a building or other solid structure.
- 15 Towers shall only be moved manually and only on firm level ground which is free from obstacles. Normal walking speed shall not be exceeded during relocation.

Before Moving

- 1 Make sure the tower is within recommended base height to base ratios for moving (ie 2.5 times the smallest base dimension). Dismantle to correct height if necessary .
- 2 Do Not attempt to move the tower with any leg extended more than 100mm.
- 3 Never attempt to move the tower with men or materials on it. Remove ties if fitted.
- 4 Always be aware of any overhead hazards and make sure that the route to be taken is level and there are no holes or other obstructions.
- 5 Push manually and at the base only.

After Moving The Tower

- 1 Relock castors and ensure that the tower is both vertically & horizontally aligned.
- 2 Reposition stabilisers and ensure they have safe footing.
- 3 Where necessary re tie the tower to a rigid structure.
- 4 Do not suspend mobile access towers without referring to your supplier.
- 5 A tower must be kept in good working order and therefore a competent person should inspect the tower at least once a week to check damage to the components and that the tower has not been altered in any way. Any parts found to be faulty or missing should be immediately replaced.

When Dismantling The Tower

- 1 Keep to the Instructions in this guide.
- 2 Never throw equipment from the tower.
- 3 Always lower equipment down to ground level by rope or hand.
- 4 Always report damaged equipment. Equipment should be maintained in a serviceable condition.

LYTE Industrial Folding Tower - FT150E

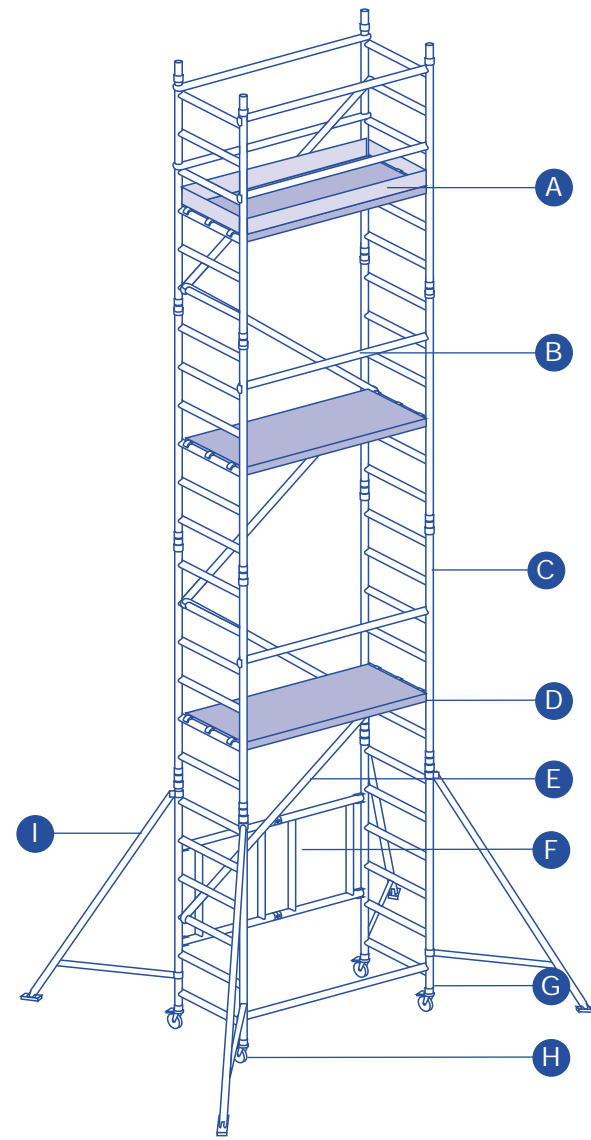

- A - Toeboard Set F - Base Unit
 B - Horizontal Brace G - Adjustable Leg
 C - Standard Frame H - Castor
 D - Platform I - Stabilizer Unit
 E - Diagonal Brace

Maximum Safe Working Loads

The maximum safe working load for the Folding Tower is 950kg. This is to include the tower self weight.

The maximum capacity of each working level is 275kg, regardless of the number of decks. The individual decks have a maximum capacity of 275kg.

Components for the FT150E Weight

125mm Locking Castor (Standard)	1.20kg
150mm Locking Castor (for adjustable leg only)	3.54kg
Adjustable Leg (optional)	0.98kg
1.5m Base Unit	15.00kg
1.5m Frame	5.60kg
1.8m Hatchdeck	13.40kg
1m Guardrail	3.80kg
1.8m Horizontal Brace (Ribbed)	2.05kg
2.1m Diagonal Brace (Smooth)	2.20kg
1.8m Side Toe Board	2.90kg
1.2m End Toe Board	1.94kg
Standard Stabilizer	3.80kg
Telescopic Stabiliser	8.20kg

Assembly Checklist

- 1 Always inspect components before erecting the tower.
- 2 Always inspect the tower before using.
- 3 Ensure that the tower is upright.
- 4 Ensure castors are locked
- 5 Ensure legs are correctly adjusted
- 6 Ensure all Horizontals, Verticals & Platforms are level
- 7 Ensure stabilisers are fitted as specified in the instruction manual
- 8 Ensure platforms are correctly located & anti lift locks are on.
- 9 Ensure all handrails are in place
- 10 Ensure Toe Boards are correctly fitted as described in the instruction manual.
- 11 Ensure knuckle joint is secured with locking pin.

Always refer to this checklist before and after erection of the tower

If in doubt about any application consult your supplier for advice.

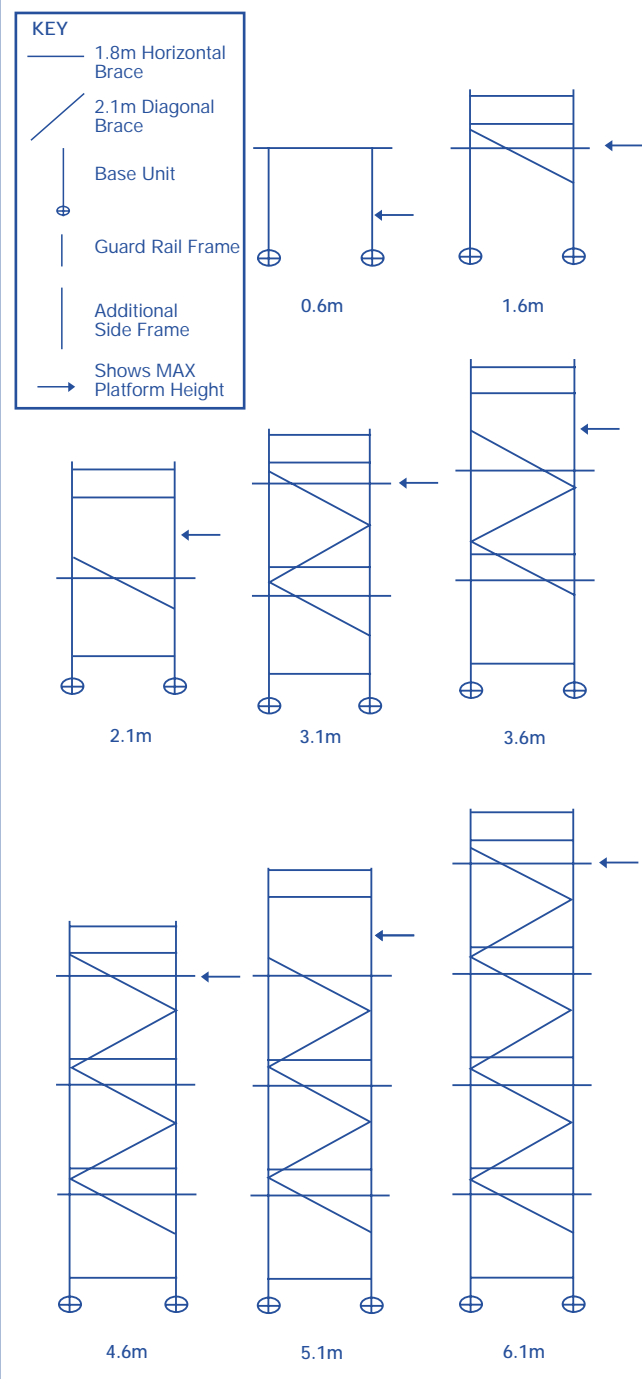

LYTE TOWERS

Lyte Ladders Wind Rd, Ystradgynlais, Powys, UK SA9 1FY

Telephone: 01639 846800 Sales Fax: 01639 841541
 Email: sales@lytetowers.co.uk

Toeboard Fitting

- 1 Stand 1 x long Toe Board section with link clamp facing down & 1 x short Toe Board section with link clamp facing up as shown in Toe Board fitting instructions diagram 1.

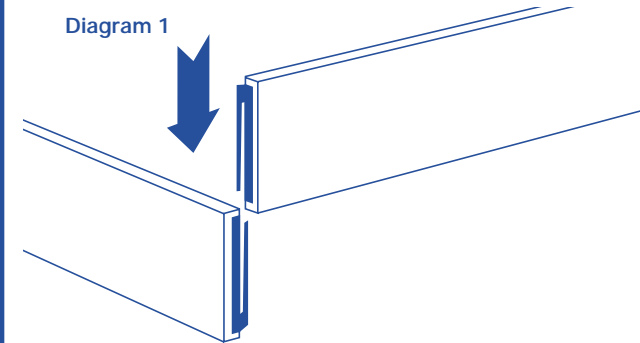

- 2 Slide long Toe Board link clamp down onto upward facing link clamp on short Toe Board. Ensure that the two boards are firmly linked.

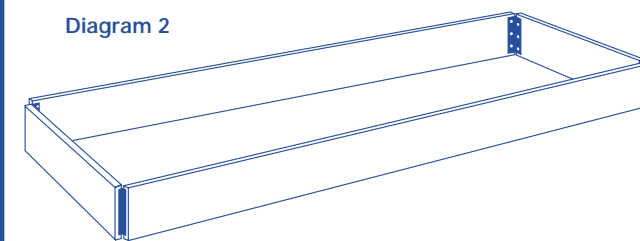

- 3 Repeat step 1 & 2 until all 4 Toe Board sections are in place as shown in diagram 2.

LYTE TOWERS

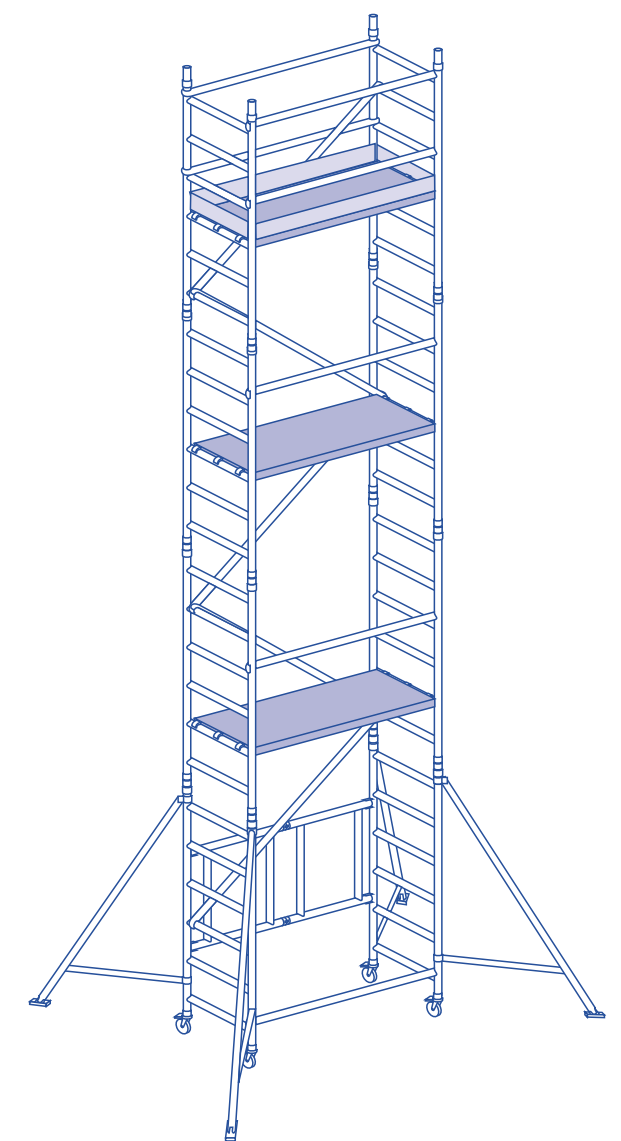

Tower Assembly Instructions for
 Lyte Industrial Folding Tower
 System Type FT150E Only

1

Open frame from folded position until knuckle joint is closed. Secure joint with locking pin. Activate brake system on castors.

2

If only base section is to be used position deck on second rung, secure with locking brace. However if additional frames are to be used fit a horizontal brace to base as shown in the diagram. If using the Tower on uneven levels, fit the system with adjustable legs and castors.

NOTE: Adjustable legs are not intended to be used to gain extra height.

• Correct way to climb onto platform

3

When fitting extra frames disengage spring clips from frame sections.

4

Insert additional frame into base section and engage clips, secure with diagonal brace to the third rung of the base unit.

5

Fit second additional frame and engage clips, secure using a diagonal brace as shown below.

7 Position hatch deck at required platform height - see quantity schedule. Secure platform with locking braces.

8 Guard rails must be fitted at a height of 1 metre (+ - 50mm) from the working platform, with an intermediate guardrail fitted allowing a maximum gap of 470mm. To achieve this, fit four horizontal braces, secured to the side frames as shown.

9 Toeboards must be fitted on all work platforms from which tooling or equipment is liable to fall 2 metres or more. Although their use on intermediate, or rest platforms is not compulsory - unless a risk assessment identifies a risk that an item, such as tooling and/or materials may be stored there, and may fall from an unprotected platform.

10 If additional frames are required repeat steps four and five.

NOTE: A Hatchdeck rest platform must be placed every four metres with guardrails fitted as above.

COMPONENT SCHEDULE

	PLATFORM HEIGHT (Max)							
	0.6m	1.6m	2.1m	3.1m	3.6m	4.6m	5.1m	6.1m
125mm Locking Castor (Standard)	4	4	4	4	4	4	4	4
150mm Locking Castor (for adjustable leg only)*	4*	4*	4*	4*	4*	4*	4*	4*
Adjustable Leg (optional)*	4*	4*	4*	4*	4*	4*	4*	4*
1.5m Base Unit (Inc 1 x 1.8m Hatch Deck)	1	1	1	1	1	1	1	1
1.5m Additional Frame	0	0	2	2	4	4	6	6
1.8m Additional Hatchdeck	0	0	0	0	1	1	2	2
1.0m Guardrail Frame	0	2	0	2	0	2	0	2
1.8m Horizontal Brace (Ribbed)	0	4	5	6	6	7	7	8
2.1m Diagonal Brace (Smooth)	0	1	1	3	3	5	5	7
1.8m Toe Board Length	0	2*	2*	2	2	2	2	2
1.2m Toe Board End	0	2*	2*	2	2	2	2	2
Standard Stabiliser Unit	0	4*	4	4	4	4	4	4
Telescopic Stabiliser Unit	0	0	4*	4*	4*	4*	4*	4*

* Indicates Optional Components

6

Attach stabilizer legs, ensure all fixings are secure.

Stabilisers

Fix one stabiliser to each corner of the Tower at approx 45 degrees. Ensure top clamp is positioned under a rung casting and tighten the clamp to hold in position. Attach the bottom clamp as low down as possible (See fixing stabilisers diagram). For large stabilisers fix the middle clamp and tighten.

For telescopic stabilisers extend legs until rubber foot makes contact with the ground. Lock telescopic leg with attached spring clip. Ensure rubber feet are firmly in contact with the ground by sliding lower clamp downwards and tighten securely. Securely tighten top clamp (and mid clamp where applicable) to provide a rigid base structure.

When moving the tower lift & lock each telescopic leg clear of the ground, unlock castors ensuring area is firm & clear of all obstructions both on the ground & above. After moving check all castors are firmly on the ground & locked. Check that the tower is vertical then reposition stabilisers as described above.

Fixing Stabilisers

*** PLEASE REMEMBER**
A thorough risk assessment must be carried out prior to any work being carried out at height.